

THE CANADIAN CHEMISTRY CONTEST 2014

PART A – MULTIPLE CHOICE QUESTIONS (60 minutes)

All contestants should attempt this part of the contest before proceeding to Part B and/or Part C

The only reference material allowed is the CIC/CCO Periodic Table provided. Answers must be completed on the Scantron Sheet Provided

A scientific calculator is allowed. No phones or any devices that can be used for communication are allowed.

1. To safely and efficiently prepare 1.0 L of a 1.0 mol L⁻¹ solution of HCl from a 12.0 mol L⁻¹ stock solution of HCl, what should a chemist add to a 1 L volumetric flask first?

A) **500 mL of distilled water with a beaker**
 B) 120.0 mL of 12.0 mol L⁻¹ HCl with a graduated cylinder
 C) 83.3 mL of 12.0 mol L⁻¹ HCl with a graduated cylinder
 D) 12.0 mL of 12.0 mol L⁻¹ HCl with a graduated cylinder
 E) 10.0 mL of distilled water with a graduated cylinder

2. According to the Aufbau Principle in quantum mechanics, which of the following is the highest energy electron sublevel?

A) 7s B) 6p **C) 6d** D) 5f E) 5p

3. In their solid form, which of the following is made up of discrete particles (either atoms, ions or molecules) that only have London Dispersion forces of attraction between them?

A) Ag **B) CO₂** C) C, graphite D) KCl E) NH₃

4. Removing all lone pairs of electrons on the central atom of ClF₃ would change the geometry

A) from trigonal pyramidal to trigonal planar
B) from T-shaped to trigonal planar
 C) from trigonal bipyramidal to trigonal pyramidal
 D) from trigonal bipyramidal to trigonal planar
 E) minimally. The shape would remain trigonal planar.

5. Select the arrangement below that lists the bonds in order of *increasing* polarity (least polar to most polar):

A) C–F, O–F, Be–F **B) O–F, C–F, Be–F** C) Be–F, O–F, C–F
 D) Be–F, C–F, O–F E) O–F, Be–F, C–F

6. The top diagram represents the initial state of a mixture of diatomic gas A and diatomic gas B in a closed reaction flask. Which of the diagrams under the answer choices represents the contents of the flask if the reaction goes to completion? The balanced chemical equation is: A₂ + 3 B₂ → 2 AB₃

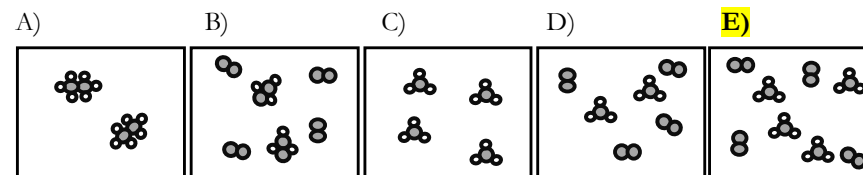
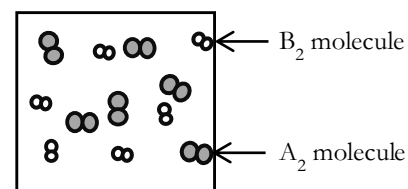

7. Calcium fluoride, CaF₂, occurs in nature principally as the mineral *fluorite* and is the primary source of industrial hydrogen fluoride. Determine the concentration of fluoride ions in a saturated solution of calcium fluoride with [Ca²⁺] = 0.0250 mol L⁻¹. K_{sp} for calcium fluoride is 3.45 x 10⁻¹¹.

A) 1.38 x 10⁻⁹ mol L⁻¹ B) 2.76 x 10⁻⁹ mol L⁻¹ C) 5.87 x 10⁻⁶ mol L⁻¹
D) 3.71 x 10⁻⁵ mol L⁻¹ E) 1.85 x 10⁻⁵ mol L⁻¹

8. A closed 2.0 L container initially holds 4.0 mol of oxygen and 2.0 mol of nitrogen at temperature T. If the pressure remains constant when 2.0 mol of oxygen are removed, which expression correctly describes the final temperature of the system in terms of the initial temperature, T? Assume Ideal Gas behaviour.

A) **3T/2** B) 2T C) 2T/3 D) 3T E) T

9. In the television series *Breaking Bad*, Walter White and Jesse Pinkman synthesize methamphetamine (*N*-methyl-1-phenyl-2-propanamine) which is marketed as methamphetamine hydrochloride, or “crystal meth”.

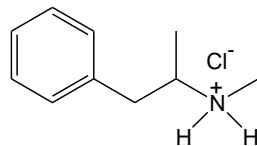

methamphetamine hydrochloride

What is the molecular formula of methamphetamine hydrochloride?

- A) C₈H₁₆ClN B) C₁₀H₁₀ClN **C) C₁₀H₁₆ClN**
 D) C₁₀H₁₄ClN E) C₉H₁₆ClN
10. Referring to question #9, in the structure of methamphetamine hydrochloride, how many non-bonding valence shell electrons are there? Lone valence electrons are single valence electrons that are not involved in covalent bonds.
- A) 4 B) 6 C) 7 **D) 8** E) 10
11. What is the final temperature of a mixture of 50.0 g of Cu (specific heat capacity = 0.3845 J g⁻¹ °C⁻¹) initially at 135.0°C and 150.0 mL of water (specific heat capacity = 4.184 J g⁻¹ °C⁻¹) initially at 21.0 °C? Assume that there is no loss of heat and the container has a negligible heat capacity.
- A) 17.4°C B) 22.5°C **C) 24.4°C** D) 35.2°C E) 78.0°C
12. Consider the following potential energy diagram for the reaction AB + C → AC + B.

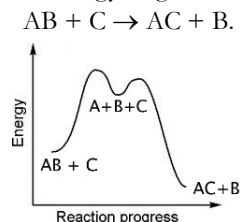

What is/are the reaction intermediate(s) in this reaction?

- A) AB and C B) B C) AC and B
 D) A, B and C **E) A**

13. In the *emergency oxygen system* on commercial passenger aircraft, sodium chlorate undergoes thermal decomposition to produce oxygen gas:

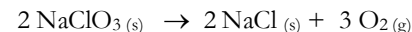

On average a human under stress consumes 38.0 L of O₂ through respiration every 15 minutes. Determine the *minimum* mass of sodium chlorate required to deliver this volume of O₂ (assume *P*= 100 kPa and *T*= 273.15 K)

- A) 65.0 g **B) 119 g** C) 178 g D) 267 g E) 356 g
14. The reaction to convert iron (II) oxide to iron (III) oxide is as follows:

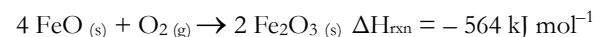

If the enthalpy of formation (ΔH_f°) of rust (Fe₂O_{3(s)}) is -826 kJ mol⁻¹, what is the enthalpy of formation of FeO in kJ mol⁻¹?

- A) -554 **B) -272** C) +272 D) -262 E) +262
15. The chemical reaction that takes place when 1.30 g of pure zinc is mixed with 400 mL of a 0.100 mol L⁻¹ copper (II) chloride solution is :

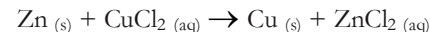

Which diagram best represents the system after the reaction has gone to completion? Answer: **Flask D**

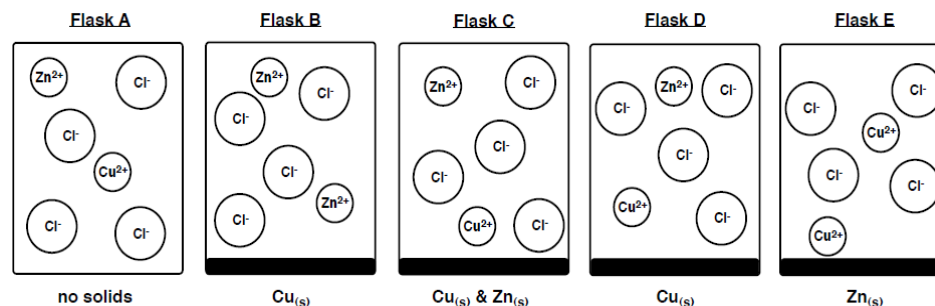

16. Iron(III) is readily hydrated in aqueous solution and subsequently undergoes hydrolysis according to the following equations:

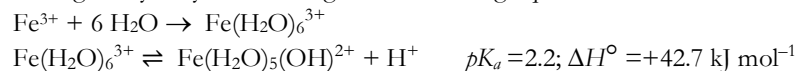

Predict the effect of an increase in temperature on the pK_a and the $[\text{H}^+]$ of the solution.

- A) pK_a increases, $[\text{H}^+]$ decreases B) pK_a increases, $[\text{H}^+]$ increases
C) pK_a decreases, $[\text{H}^+]$ decreases D) pK_a decreases, $[\text{H}^+]$ increases
 E) pK_a unchanged, $[\text{H}^+]$ unchanged
17. One of the Twelve Principles of Green Chemistry is that “synthetic methods should be designed to maximize the incorporation of all materials used in the process into the final product”. One way to consider this is to calculate the *atom economy* (AE) of a chemical reaction where AE is defined as follows:

$$\text{atom economy} = \frac{\text{molecular mass of desired product}}{\text{molecular mass of all reactants}} \times 100\%$$

1,4-Dimethoxybenzene is an organic compound with an intensely sweet floral odour and used in the perfumery industry. It can be synthesized in the laboratory by the reaction shown below:

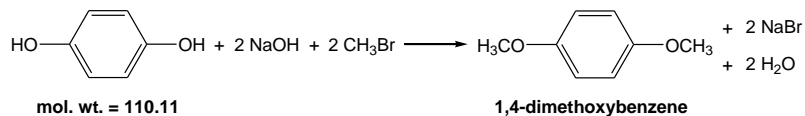

What is the percentage atom economy for this reaction?

- A) 46.1% **B) 36.3%** C) 56.4% D) 67.4% E) 20.6%
18. The reaction $2 \text{A} + \text{B}_2 \rightarrow 2 \text{AB}$ is first order in $[\text{B}_2]$ and zero order in $[\text{A}]$. The half-life for the overall reaction is 2 minutes. If 0.100 moles of A and 0.0300 moles of B₂ are dissolved in 100.0 mL of solvent, what will $[\text{A}]$ be, 6.00 minutes after the reaction begins?

- A) 0.00125 mol L⁻¹ B) 0.125 mol L⁻¹ C) 0.00375 mol L⁻¹
 D) 0.738 mol L⁻¹ **E) 0.475 mol L⁻¹**

19. A galvanic cell is created for the following reaction:



A light bulb is connected to the cell and allowed to glow until it dies out. Doubling the mass of the electrodes and volumes of solutions will have which of the following effects?

- I. The light bulb will glow twice as bright.
 II. Twice as much heat will be generated.
 III. The light bulb will glow twice as long.
- A) II only B) I and II C) I and III **D) II and III** E) I, II, and III
20. To create a nickel-plated electrode using a 1.5 V battery, what are the most appropriate choices for A, B, and C in the diagram of the electrolytic cell below?

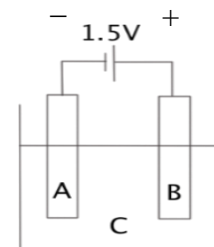
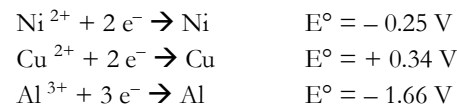

	A	B	C
A)	Ni	Cu	CuSO ₄
B)	Ni	Cu	NiSO ₄
C)	Cu	Ni	NiSO₄
D)	Ni	Al	Al ₂ (SO ₄) ₃
E)	Al	Ni	NiSO ₄

21. Hemoglobin is the iron-containing protein in red blood cells that transports oxygen to cells and tissues. Four oxygen molecules bond with each hemoglobin molecule to form oxygenated hemoglobin, $\text{Hb}(\text{O}_2)_4$. The production of oxygenated hemoglobin can be depicted by the following equilibrium:

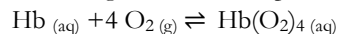

At high altitudes, the total atmospheric pressure decreases and thus the partial pressure of oxygen decreases. With insufficient oxygenated hemoglobin, a person will feel light-headed and eventually lose consciousness. Which of the following statements is TRUE about the hemoglobin equilibrium reaction as a person climbs to a high altitude?

- A) The concentration of the products increases
B) The rate of the reverse reaction increases
C) The reaction quotient (Q) will increase
 D) The concentrations of the aqueous solutions will not change
 E) The value of the equilibrium constant increases
22. Given the following standard reference values at 25°C and 100 kPa, which of the following combination of thermodynamic values describes a reaction that is endothermic and spontaneous at 2000 °C? Assume enthalpy and entropy values are not temperature dependent.

	$\Delta H^\circ(\text{kJ mol}^{-1})$	$\Delta S^\circ(\text{J mol}^{-1} \text{K}^{-1})$	$\Delta G^\circ(\text{kJ mol}^{-1})$
A)	217.0	115.0	182.7
B)	- 230.0	- 11.0	- 226.7
C)	52.0	10.0	49.0
D)	- 363.0	249.0	- 437.2
E)	268.6	- 88.0	294.8

23. To determine the concentration of 10.00 mL of a solution of H_2SO_3 of unknown concentration, a 10.00 mL sample of the unknown H_2SO_3 is diluted to 100.00 mL and 25.00 mL of the diluted H_2SO_3 is titrated with 0.1178 mol L^{-1} sodium hydroxide. The complete neutralization of the unknown H_2SO_3 requires 32.45 mL of the NaOH solution. What is the concentration of the original H_2SO_3 solution?

- A) 0.01529 mol L^{-1} B) 0.07645 mol L^{-1} C) 0.1529 mol L^{-1}
D) 0.7645 mol L^{-1} E) 1.529 mol L^{-1}

24. Which diagram best depicts an aqueous solution of dilute hydrofluoric acid?

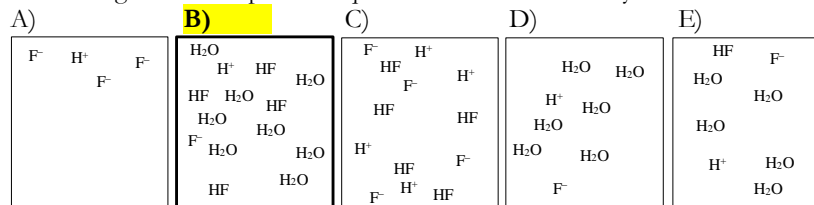

25. The following is a titration curve of a weak acid by a strong base. What is the $[\text{H}_3\text{O}^+]$ in mol L^{-1} at equivalence?

- A) **1.6×10^{-9}** B) 8.8×10^{-8} C) 1.0×10^{-7} D) 0.010 E) 0.94

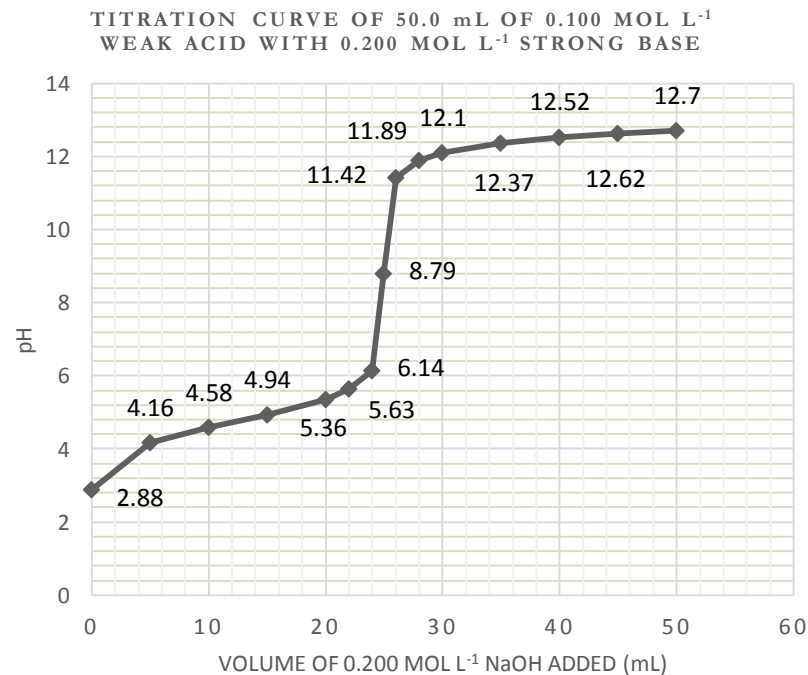

**End of Part A of the contest.
 Now go back and check your work**